

# NAO<sup>6</sup>

Datasheet

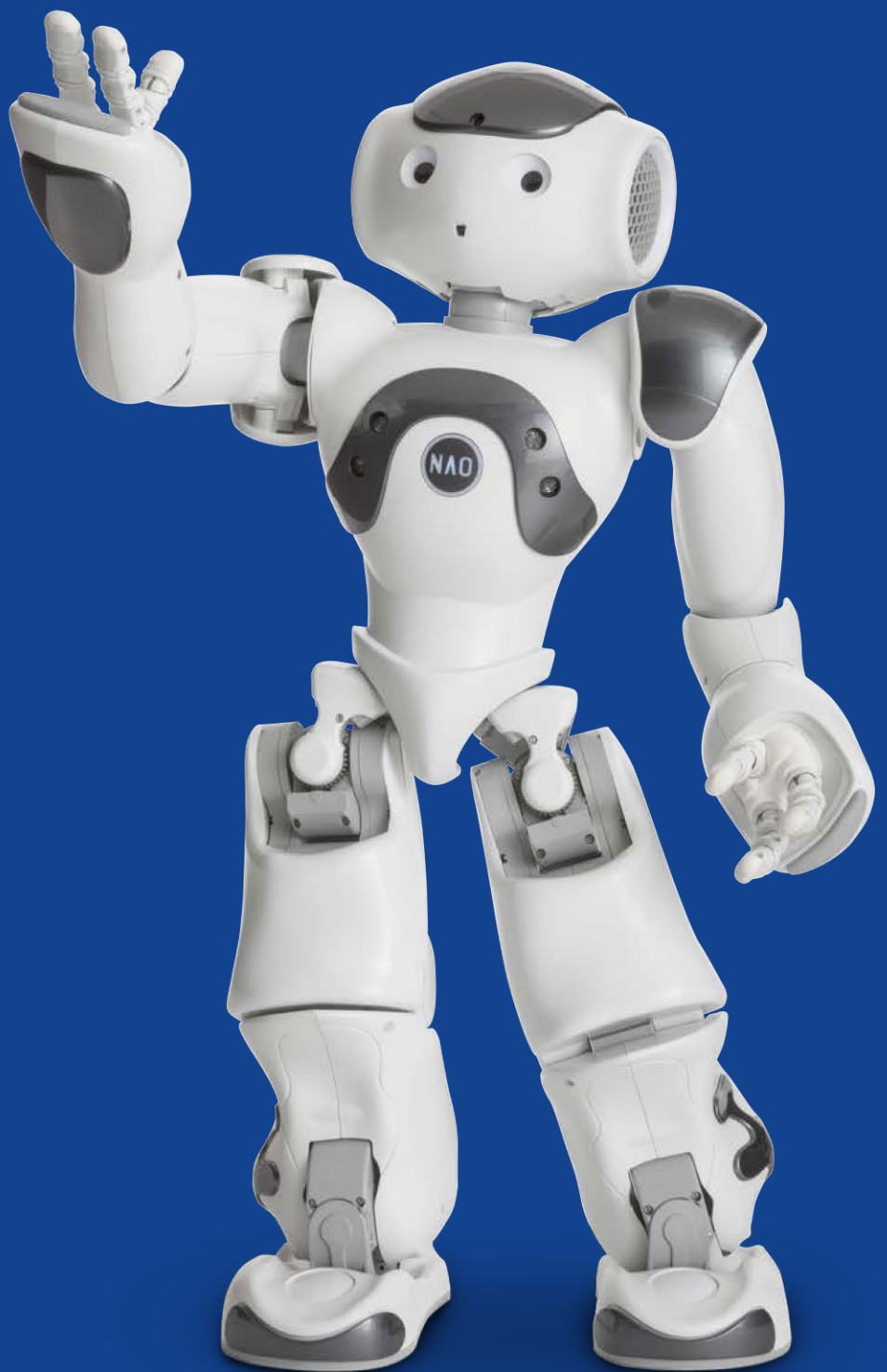

MODEL: H25600

## PHYSICAL CHARACTERISTICS

### GENERAL

Size (HxDxW)	574x311x275 mm / 22.6x12.2x10.8 in
Weight	5.48 kg / 12.08 lb

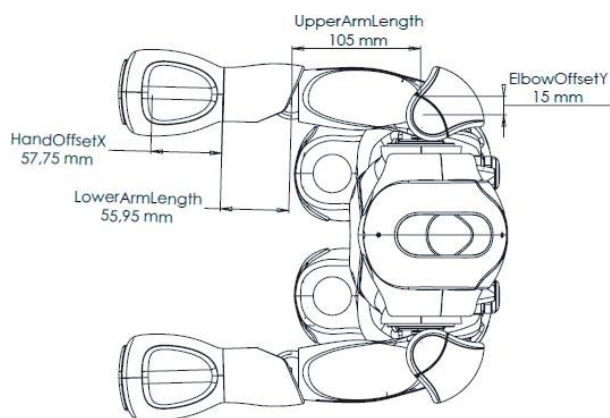
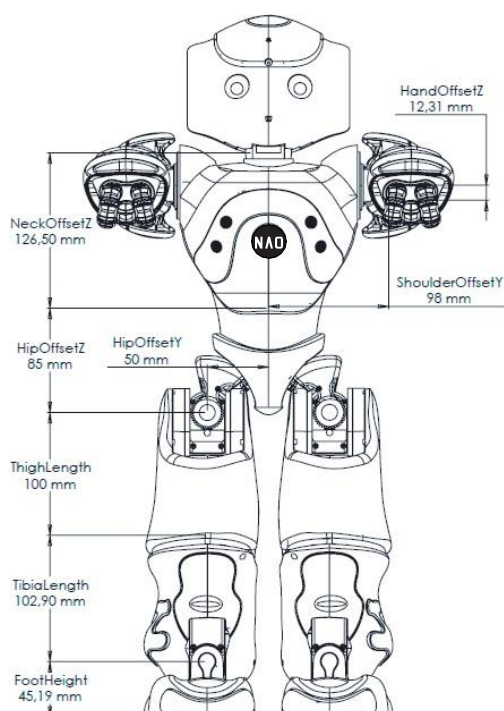

## BRAIN SYSTEM

### MOTHERBOARD

CPU	CPU processor	ATOM E3845
	Cache memory	2 MB
	Clock speed	191 GHz

RAM 4 GB DDR3

Flash memory 32 GB eMMC

## HUMAN INTERACTION

### LANGUAGES

Text to speech & Automatic speech Recognition  
 Czech, Danish, Dutch, English, Finnish, French, German, Italian, Japanese, Greek, Polish, European Portuguese, Brazilian Portuguese, Spanish, Swedish, Russian, Turkish, Arabic, Brazilian, Standard Mandarin, Taiwanese Mandarin, Norwegian.

### AUDIO

Loud Speakers	Left & Right	
	Diameter	40 mm
	Impedance	4 Ω
	Audio power	87 dB +/- 3 dB
	Freq range	up to ~20 kHz
Input	2 W	

Microphones	x4 omnidirectional on the head	
	Sensitivity	-12dBV/PA @1KHZ
	Frequency range	100HZ to 10KHZ

### LEDS

Placement	Quantity	Description
Tactile Head	12	16 White levels
Eyes	2x8	RGB FullColor
Ears	2x10	16 Blue levels
Chest button	1	RGB FullColor
Feet	2x1	RGB FullColor

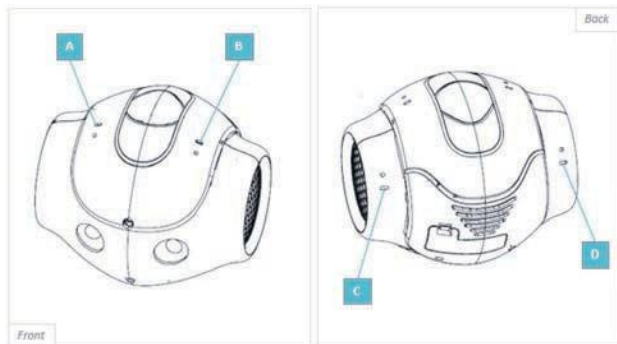

## 2D CAMERAS

Cameras	2 front of head	
Sensor model	OV5640	
Sensor type	SoC - CMOS Image Sensor	
Imaging array	Resolution	5 MP
	Size	1/4 in
	Active Pixels (HxV)	2592 x 1944
Sensitivity	Pixel size	14 x 14 $\mu\text{m}$
	Dynamic range	68 dB @8x gain
	Signal/Noise ratio (max)	36 dB
	Responsivity	600 mV/lux-sec
Output	Camera output	640 x 480 @30 fps
	Data Format	YUY & RGB
	Shutter type	Rolling Shutter/ frame exposure
View	Field of view	67.4° DFOV (56.3° HFOV, 43.7° VFOV)
	Focus range	10 cm $\sim\infty$ $\approx$ 4 in - $\infty$
	Focus type	Auto focus

## FRAMERATES

Resolution	Top Camera	Bottom Camera
320x240 px	@15, 30 fps	@15, 30 fps
640x480 px	@15, 30 fps	@15, 30 fps
1280x960 px	@15, 30 fps	@10, 15 fps
1920x1080 px	@15, 30 fps	-
2560x1920 px	@15 fps	-

Note: The rate of the video stream will depend on the network and the video resolution chosen. All frame rates depend on the CPU usage. Values are measured with a CPU fully dedicated to image gathering.

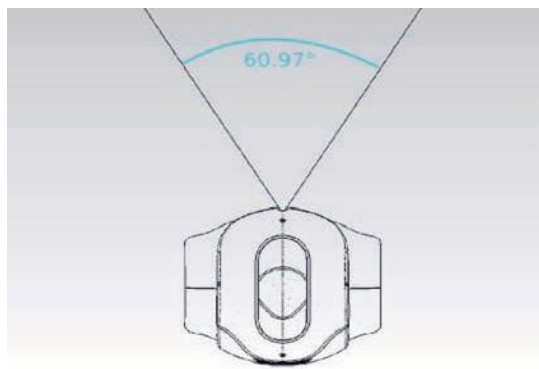
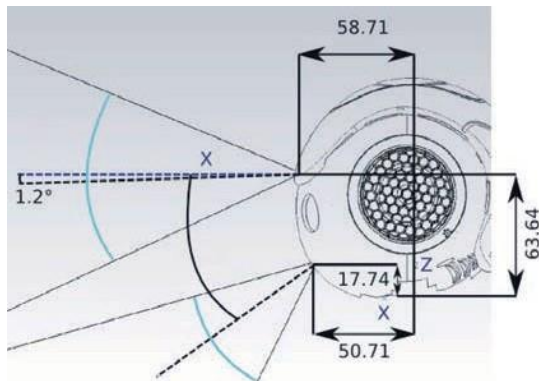

## ENVIRONMENT SENSORS

### INERTIAL UNIT

Gyrometer	1	
	Axis	3
	Precision	5%
	Angular speed	500°/s approx.
IMU	1	
	Axis	3
	Precision	10%
	Angular speed	2 g approx.

## SONAR

Transmitters	2 on front
Receivers	2 on front
Frequency	40 kHz
Resolution	1cm @50 cm
Detection Range	0.20 m to 0.80 m
Effective Cone	60°

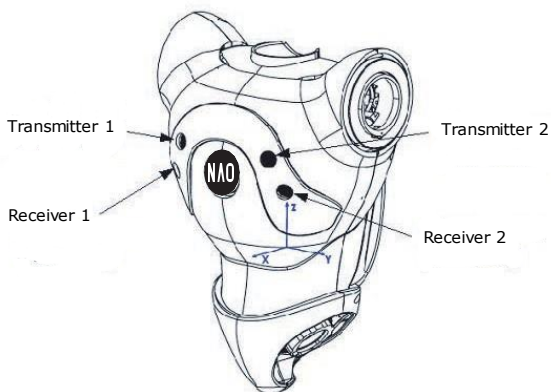

## FORCE SENSITIVE RESISTORS (FSR)

Range	0 to 25 N
Location	4 in each foot
Sensitivity	40 g approx.

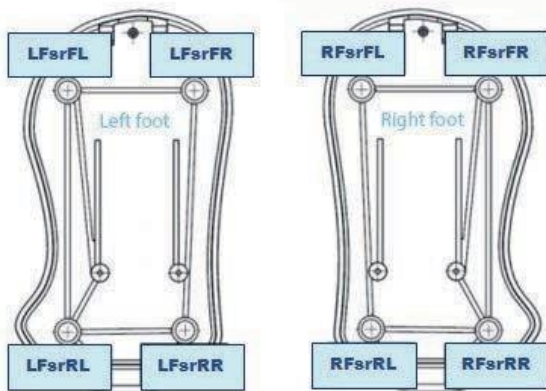

## BUTTONS & SENSORS

Chest Button	✓
Foot Bumper	✓
Tactile Head	✓
Tactile Hand	✓

## ENERGY

### ROBOT BATTERY

Battery	Type	Lithium-Ion
	Nominal voltage/capacity	21.6 V / 2.9 Ah
	Max charge voltage	25.2 V
	Recommended charge current	1.8 A
	Max charge / discharge current	2.1 A / 2.0 A
	Energy	62.5 Wh
	Charging duration	90 min
	Run time	60 min (Active use) 90 min (Normal use)

### BATTERY CHARGER

Input	100 to 240 VAC – 50/60 Hz – Max 12 A
Output	25.2 VDC – 2 A

## MOTION

### DEGREES OF FREEDOM

Head	2
Arm (in each)	5
Pelvis	1
Leg (in each)	5
Hand (in each)	1

## MOTOR SPECIFICATIONS

Motor type    Brush DC Coreless

## POSITION OF MOTORS

		Gear Ratio	Motor type
Head joints	HeadYaw	150.27	3
	HeadPitch	173.22	3
Arm joints	ShoulderPitch	150.27	4
	ShoulderRoll	173.22	3
	ElbowYaw	150.27	3
	ElbowRoll	173.22	3
Arm joints	WristYaw	50.61	2
	Hand/ Fingers	36.24	2
Leg joints	HipYawPitch	201.3	1
	HipRoll	201.3	1
	HipPitch	130.85	5
	KneePitch	130.85	5
	AnklePitch	130.85	5
	AnkleRoll	201.3	1

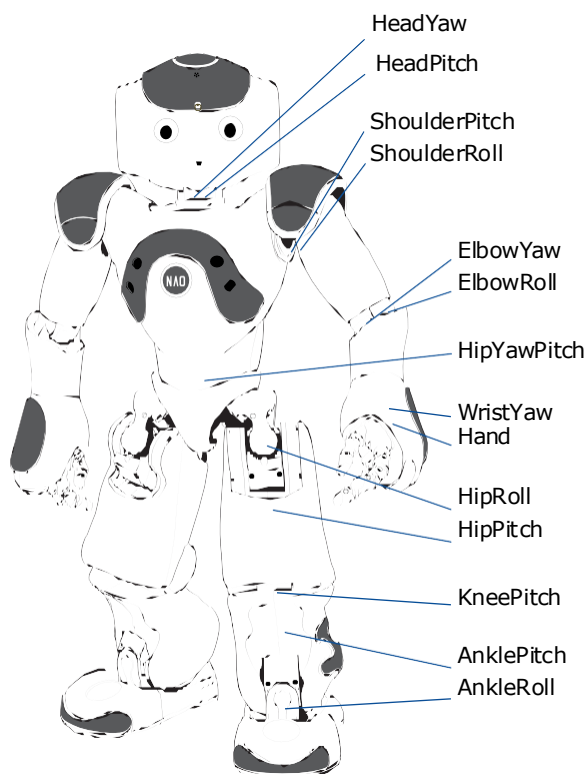

For details of type and gear ratio, see below.

## MOTOR TYPE

	Motor type 1	Motor type 2	Motor type 3	Motor type 4	Motor type 5
Make	22NT82213P	17N88208E	16GT83210E	DCX 16S	22NT Z20
No load speed (rpm)	8700 ±10%	8400 ±12%	10700 ±10%	11400 ±10%	8700 ±10%
Stall torque (mNm)	65 ±8%	9.4 ±8%	14.3 ±8%	22.4 ±10%	65 ±10%
Continuous torque (mNm)	17.8 max	4.9 max	6.2 max	2.6 max	17.8 max

## JOINT MOVEMENT ENCODERS

MRE                    36  
(Magnetic Rotary    Using hall effect sensor technology  
Encoder)              Precision: 12bits / 0.1°

## CONNECTIVITY

### CONNECTION

Ethernet 1xRJ45 - 10/100/1000 BASE T

WIFI IEEE 802.11a/b/g/n

WPAN IEEE 802.15.1 4.0 (LE)  
(Bluetooth)

### SOFTWARE

Open Nao Embedded GNU/Linux  
Distribution based on Gentoo

Architecture 86

Programming Embedded: C++ /Python  
Remote: Java